

## Engineering Submittal - CX Series Combi Boilers



Job Name \_\_\_\_\_

Address \_\_\_\_\_

Designer / Engineer \_\_\_\_\_

Wholesaler \_\_\_\_\_

Contractor \_\_\_\_\_

Model / Quantity     CX 150 \_\_\_\_     CX 199 \_\_\_\_

Date \_\_\_\_\_

Fuel type     Natural gas     Propane (from factory)     Propane (fuel conversion)

### Features

- » ASME approved pressure vessel constructed of high quality 439 Stainless Steel
- » Heat exchanger performance maximized through a multi-tube, counter-flow fire-tube design
- » Vertical combustion chamber and a down-firing burner allow gravity condensate drainage
- » Turn-down ratio of 10 to 1
- » 50 psi maximum pressure
- » Metal fiber knit burner
- » Direct spark ignition
- » Brushless DC fan
- » Zero governing gas valve
- » Boiler shipped with 30 psi relief valve

### Certifications

- » Constructed in accord with ANSI Z21.13-2017, CSA 4.9-2017 and the ASME Boiler and Pressure Vessel Code, Section IV and bear the H stamp as per ASME code.
- » SIM+ certified to CSA STD C22.2 #60730-2-5 and conforming to UL STD 60730-2-5 & ANSI STD Z21.20

## **SIM+ (Safety Ignition Module)**

- » SIM+ certified to CSA STD C22.2 #60730-2-5 and conforming to UL STD 60730-2-5 & ANSI STD Z21.20
- » Provides ignition, flame proving and safety monitoring, including:
  - » Electronic, probe-type Manual Reset Low Water Cut-Off
  - » High Vent Temperature safety limit
  - » Internal Manual Reset Electronic High limit with verification test
  - » Fan Operation control
  - » DC gas valve control

## **Boiler Control**

- » Clear LCD display with new, user-friendly “app-like” interface
- » Outdoor Reset function modulates boiler water temperature according to outside air temperature
- » Internal multiple boiler staging and rotation control for management of up to four boilers
- » Software upgradable by internet or by USB port
- » Accepts an external 0-10 VDC or 4-20 mA input signal
- » Multiple load control with relays for five pumps
- » Prioritizes up to four temperature circuits electrically for maximum fuel efficiencies
- » Zoning feature for control of up to four load pumps for identical temperatures
- » Load combining software for simultaneous running of compatible loads
- » Load configuration save and export to USB
- » Summer shutdown programmable by load
- » Automatic altitude compensation to 12,000 ft
- » Electronic water pressure sensing, for digital display of system pressure
- » Two Interlock connections allowing external devices to effect a boiler safety shut-down
- » Alarm dry contact for connection to external device
- » Error log with detailed conditions capture
- » User-defined unoccupied mode and DHW tank temperature (when using sensor)
- » Variable speed output signal
- » Easily set up load parameters
- » Thermostat ground terminal for power-stealing thermostat wiring
- » Electronic  $\Delta T$  fence of 40°F (22.2°C) to prevent thermal stress to boiler

## Ignition Timings

Ignition Stages Timings	
Fan Pre-purge	15 seconds
Trial for Ignition	4 seconds
Flame Failure Response	<0.8 second

## Warranties

- » Warranties are against defects in materials or workmanship and failures due to thermal shock only.
- » For residential applications, the boiler carries a five (5) year limited warranty on parts (including the DHW heat exchanger).
- » For residential applications, the boiler combustion heat exchanger (space heating) carries a 15 year warranty with registration, according to the following terms: 0-10 years (full 100% warranty), 11-15 years (25% warranty), or a five (5) year limited (100% warranty) with no registration.
- » For commercial applications, the boiler has a five (5) year limited warranty on the combustion heat exchanger (space heating), and a two (2) year limited warranty on parts (including the DHW heat exchanger).

## IBC Portal

- » Registering through an Ethernet connection gives remote access to controller functions
- » Technician's View optimized for a browser
- » Contractor or end user can receive email alerts for error states

## Connection Specifications

	Description	CX 150	CX 199
A	Flue Outlet	3" Schedule 40 or 3" PP (80 mm)	3" Schedule 40 or 3" PP (80 mm)
B	Combustion Air Inlet	3" Schedule 40 or 3" PP (80 mm)	3" Schedule 40 or 3" PP (80 mm)
C	Boiler Return Water Inlet	1" NPT-M	1" NPT-M
D	Boiler Supply Water Outlet	1" NPT-M	1" NPT-M
E	Condensate Outlet	¾" Hose	¾" Hose
F	Gas Inlet	½" NPT-F	½" NPT-F
G	DHW outlet (hot water)	¾" NPT-M	¾" NPT-M
H	DHW inlet (cold water)	¾" NPT-M	¾" NPT-M

## CX 150 Dimensions

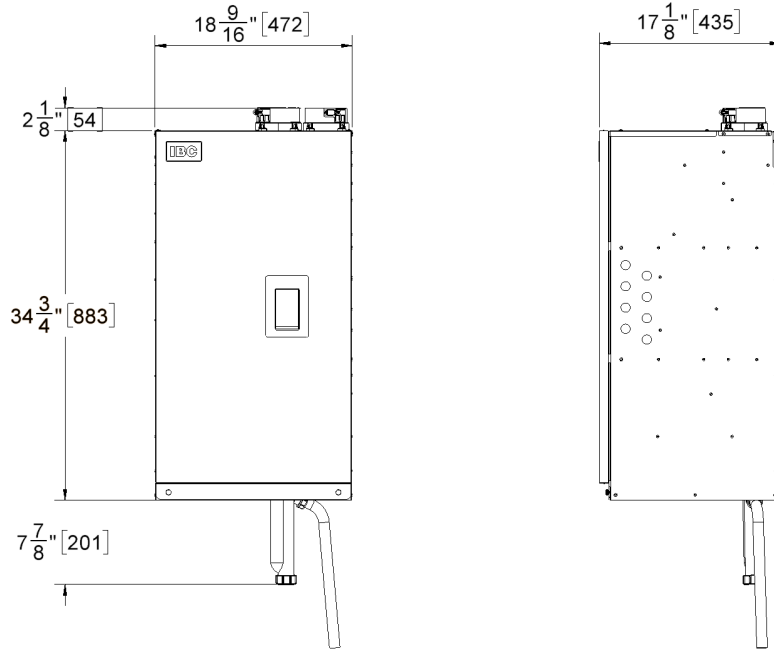

Figure 1 Front and side view - CX 150

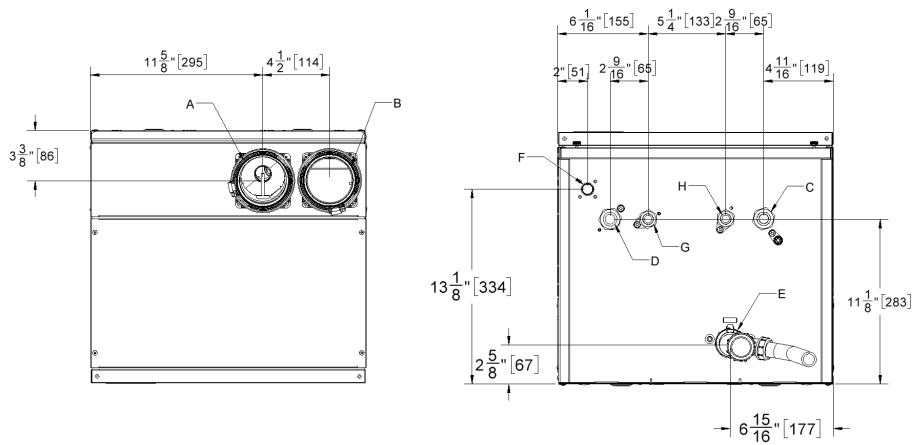

Figure 2 Top and bottom view - CX 150

## CX 199 Dimensions

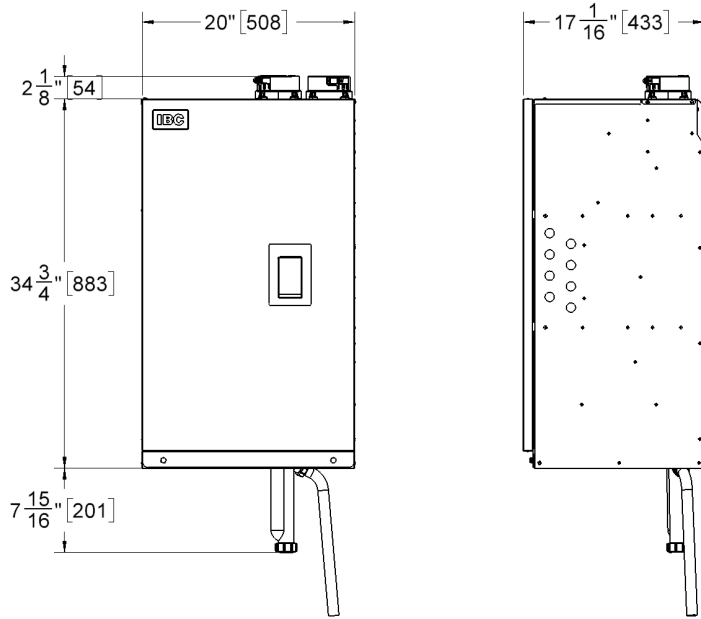

Figure 3 Front and side view - CX 199

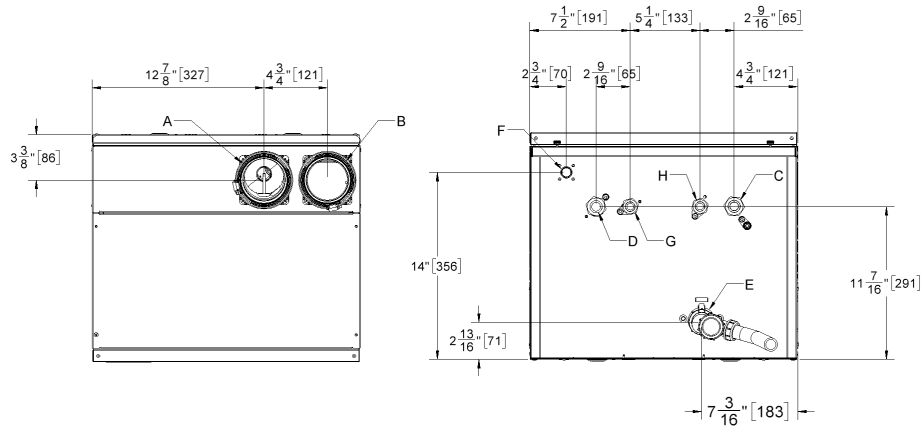

Figure 4 Top and bottom view - CX 199

## Product Specifications

Specification	CX 150	CX 199
CSA Input (Natural Gas or Propane)	15 - 150 MBH	20 - 199 MBH
CSA Input (Natural Gas or Propane)	4.4 - 44 kW	5.9 - 58.3 kW
CSA Output	14.3 - 138.5 MBH	19.1 - 183.7 MBH
CSA Output	4.2 - 40.6 kW	5.6 - 53.8 kW
DHW - CSA Input (Natural Gas or Propane)	15 - 150 MBH	20 - 199 MBH
DHW - CSA Input (Natural Gas or Propane)	4.4 - 44 kW	5.9 - 58.3 kW
AFUE	95%	95%
Minimum gas supply pressure (natural gas or propane)	4 inch w.c.	4 inch w.c.
Maximum gas supply pressure (natural gas or propane)	14 inch w.c.	14 inch w.c.
Minimum Ambient temperature	32°F / 0°C	32°F / 0°C
Maximum Ambient temperature	122°F / 50°C	122°F / 50°C
Max. relative humidity (non-condensing)	90%	90%
Minimum water temp.	34°F / 1°C	34°F / 1°C
Maximum water temp. (electronic hi-limit)	190°F / 88°C	190°F / 88°C
Max. ΔT - supply/return (electronic fence)	40°F / 22.2°C	40°F / 22.2°C
Max. water temperature lockout limit	201°F / 94°C	201°F / 94°C
Power use (120Vac/60Hz) @ full fire (with internal pump)	224.9 Watts	234.2 Watts
Weight (empty)	100 lbs / 45.4 Kg	113 lbs / 51.3 Kg
Pressure vessel water content	2.79 USG / 10.56 L	3.51USG / 13.29 L
Maximum boiler flow rate	19 USgpm	25 USgpm
Minimum boiler flow rate	3 USgpm	4 USgpm
Maximum boiler operating water pressure*	50 psig	50 psig
Minimum boiler water pressure	8 psig	8 psig
Maximum DHW water pressure	150 psig	150 psig
Minimum DHW water pressure	40 psig	40 psig
Relief valve pressure (supplied)	30 psig	30 psig
Approved installation altitude	0 - 12,000' ASL	0 - 12,000' ASL
Maximum equivalent 2" vent length each side (vent & air intake)	50'	N/A
Maximum equivalent 3" vent length each side (vent & air intake)	170'	100'

## Clearance Distances from Boiler Mounting Sites

CX 150, CX 199		
Surface	Minimum distance from combustible surfaces	Recommended clearance for installation and service
Front	2"	24"
Rear flue connection	0"	0"
Left side	0"	4" (allow access to water connections)
Right side	1"	4" (allow access to water connections)
Top	2"	6" (for vent connections)
Bottom	0" (clearance for pipes)	12" (for condensate trap and piping)

## Available Head

The boiler pump is designed to circulate through a short primary loop only. The chart below is provided for the contractor who wishes to determine whether the internal pump can also provide adequate flow through a distribution system with a known head loss.

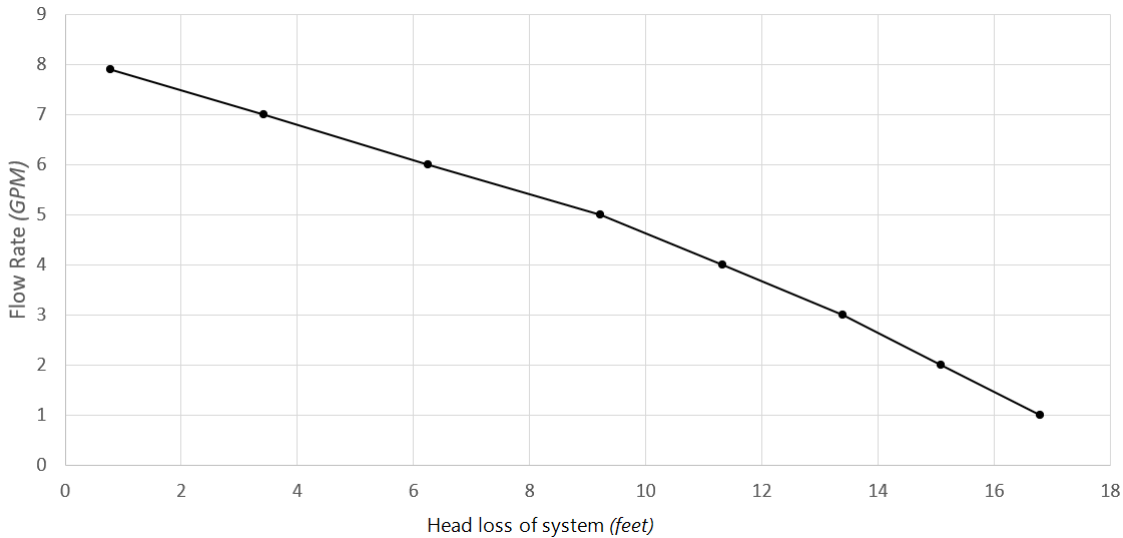

Figure 5 CX Space Heating Available head (feet) vs. Flow Rate (GPM) - Space Heating

## DHW Delivery

### Domestic Hot Water Delivery

@ 70°F / 39°C temperature rise

CX 150	4.1 GPM
CX 199	5.5 GPM

## Optional Accessories

Propane Conversion Kits:

- »  *P-1600* CX 150 qty: \_\_\_\_\_
- »  *P-1602* CX 199 qty: \_\_\_\_\_

Natural Gas Conversion Kits:

- »  *P-1601* CX 150 qty: \_\_\_\_\_
- »  *P-1603* CX 199 qty: \_\_\_\_\_
- P-216* Secondary Loop Sensor with Stainless Steel Well qty: \_\_\_\_\_
- P-1268* Communication cable (boiler network wiring, 1 required per link) qty: \_\_\_\_\_
- P-267D* Boiler stand qty: \_\_\_\_\_